

Exploring the Mechanisms of Interaction between Human Consciousness and Networks of Living Neurons

Larissa-Emilia Cheran, University of Toronto, 80 St. George Street, Toronto, Ontario, Canada, M5S 3H6 email: larisa_cheran@hotmail.com

Abstract

Can the human mind interact directly with objects, inanimate or living? Preliminary experiments performed by Dr. Larissa-Emilia Cheran at the Biosensors Laboratory, University of Toronto have shown a strong influence of human intention on cultures of neuron cells, grown on the surface of high-sensitivity sensors vibrating at 9 MHz frequency. The TSM sensor (Transverse Shear Mode Sensor) is a quartz crystal in which transverse shear mode oscillations are induced using 2 gold electrodes plated on the surfaces of the quartz crystal. The shifts in resonant frequency and motional resistance at the interface with the neuron cells are measured with high resolution and accuracy. Based on these results, future research directions are proposed.

Introduction

Experiments using neurons cultured *in vitro* on biosensor surfaces show that neurons initially go through a rapid and complex development stage - growing an elaborate neurites system, migrating to one another and aggregating in clusters, plastically absorbing, fusing and rearranging connections and finally organizing themselves in a neural network that oscillates synchronously at a specific frequency, a frequency which corresponds to the delta brain rhythm. When the cultured neural network is exposed to pharmacological stimuli, neurotrophic factors, stress hormones or neurotoxins, the frequency of this fundamental oscillation doesn't change, but the amplitude of the signal changes dramatically¹. Rhythmic synchronicity is a characteristic property of the brain, associated with cognitive processes, memory and learning. The underlying mechanisms are, however, not very well understood. *The fact that the oscillations can be detected in neuron cultures outside the brain proves that this is an intrinsic property of the self-organizing neural network, not imposed by a higher-order process from distal physiological sources.* Short and long-term consolidation of information and consciousness might be the result of such synchronized network activity. The different classes of oscillations and the behaviour patterns related to them are not found exclusively in the human brain, but they are phylogenetically preserved throughout

mammalian evolution, which would support the assumption that there is a universal mechanism at work in the brain. The alpha brain rhythm (8-12 Hz) also overlaps the Earth's background frequency of 7-10 Hz, suggesting that our state of waking and awareness is related to the rhythms of the planet we live on. Interestingly, the gamma brain rhythm (higher than 35 Hz) can be measured by an electroencephalograph both in pilots when maximally concentrating on landing a plane, as well as in the brain of Buddhist monks who have been meditating for decades; the frequency measured in these monks' brains is inexplicable much higher, around 80 Hz. Is there some form of universal consciousness oscillating at such frequencies in our brains?

One astonishing result demonstrates mind-matter interaction in an elegant and surprisingly simple way. Laboratory tests using a healer concentrating on the neuronal cultures show remarkable shifts of metabolic lines (both in resonant frequency and motional resistance characteristics).

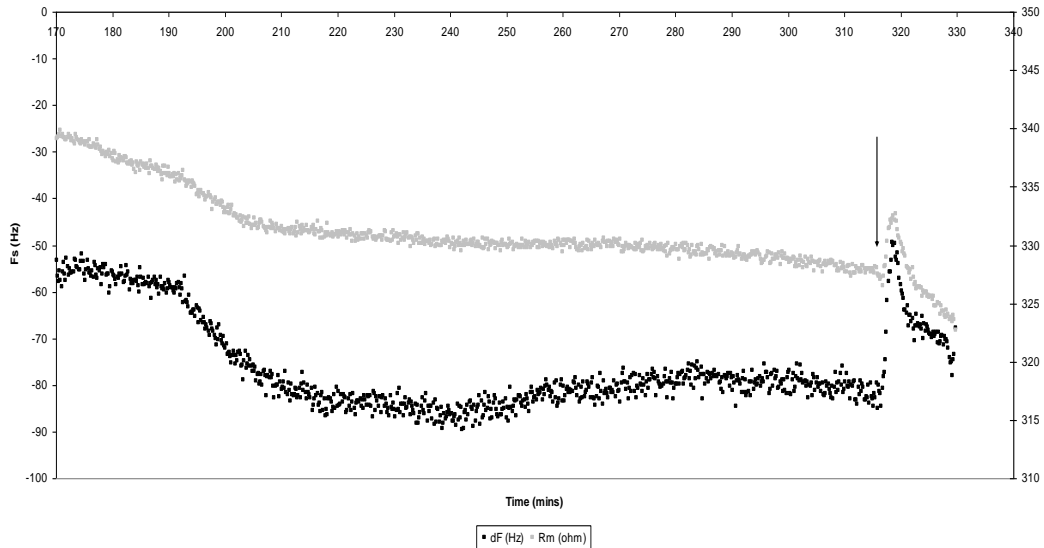

Figure 1. Shift of the metabolic lines when a human mind interacts with the neuron cultures. Until that moment, starting from the very beginning of the experiment, the control lines were horizontal and flat, showing only a normal cell metabolism. The shift represents 30Hz on the resonant frequency line (dark squares) and about 12 ohms on the motional resistance line (light squares) of the Transverse Shear Mode detecting platform. Temperature and CO₂ flux were controlled and fresh medium was pumped over the culture all the time. The arrow at the end shows where the experiment ended by stopping the pump of the flow-through cell which delivers the fresh medium.

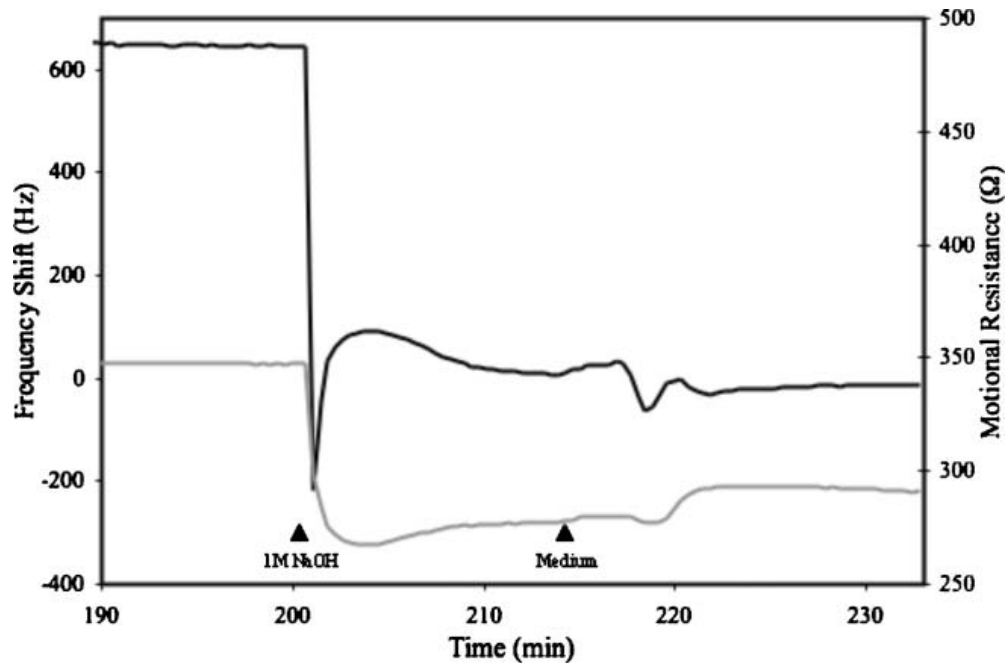

Figure 2. Control I: typical behavior of neural cell culture and potentially toxic effect of 1 M NaOH on the acoustic signal of neurons. The dark line is fs and the lighter line is Rm.

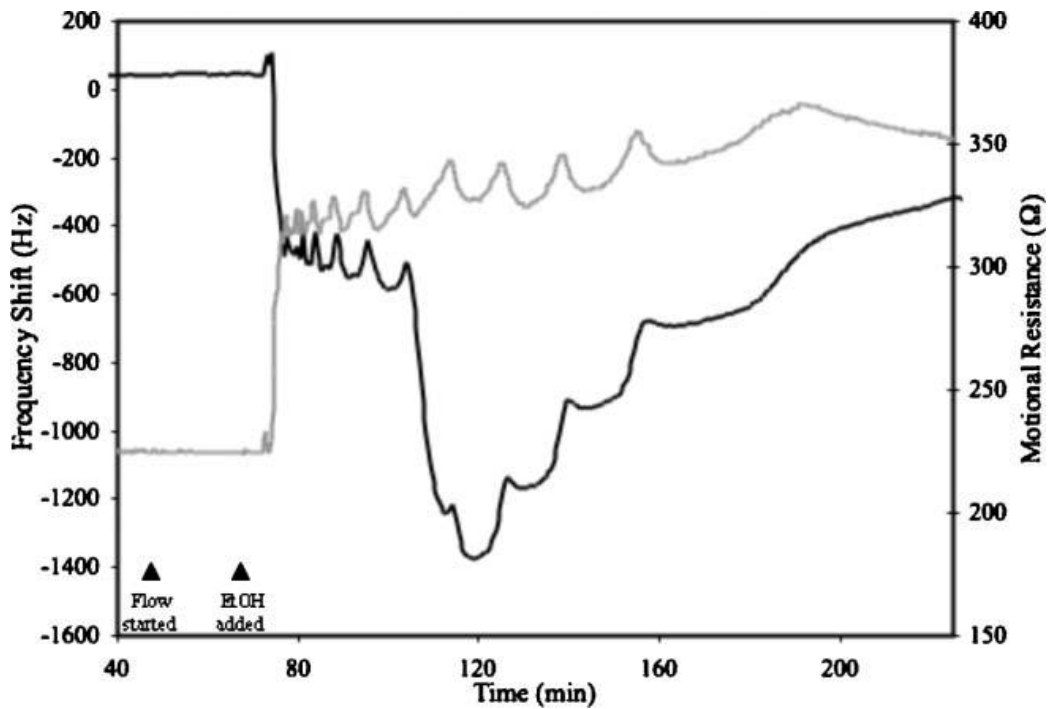

Figure 3. Control II: typical behavior of neural cell culture and Ethanol effect on neurons (added at minute 75). The dark line is fs and the lighter line is Rm.

The controls in Figures 2 and 3 (with different numbers of cells on the sensor, hence different baseline values) are showing typical flat lines prior to exposure to the neurotoxic stimulus. Since no other exterior influence was exerted on the neurons during the experiment described in Figure 1, the only cause for the change in metabolic activity is attributed to the influence of the healer. Mind-matter interaction is thus demonstrated using a transducing layer of living neuron cells interacting with a physical instrument of high sensitivity.

The experiment was done as an exploratory test and a proof of concept that the method is sensitive enough to detect such an input. We intend to investigate the possibilities more deeply, according to the research plan outlined below, in the follow-up section.

Relevance of acoustic wave sensing

Thickness shear mode (TSM) acoustic wave sensors have the capacity to analyze whole cell systems in a real-time configuration that is non-invasive, label-free and continuous, and that can be operated under a variety of temperature and liquid loading conditions. This technique has already been applied to study various neuron-drug interactions¹⁻⁵.

The interface between the neurons and the sensor can be modeled by an electrical equivalent circuit⁶ containing capacities, inductances and resistances, related to energy accumulation (inertial, elastic storage) and dissipative processes at interface. Two specific characteristics of the electrical circuit translating the neuron behaviour were considered, the resonant frequency f_s and the motional resistance R_m .

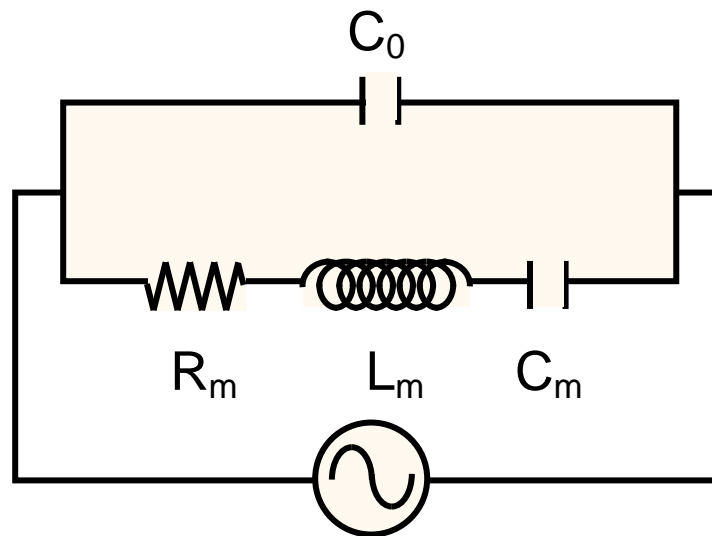

Figure 4. The electrical model of the liquid interface

At resonance, the resonant frequency is defined by:

$$f_s \approx \frac{1}{2\pi\sqrt{L_m C_m}}$$

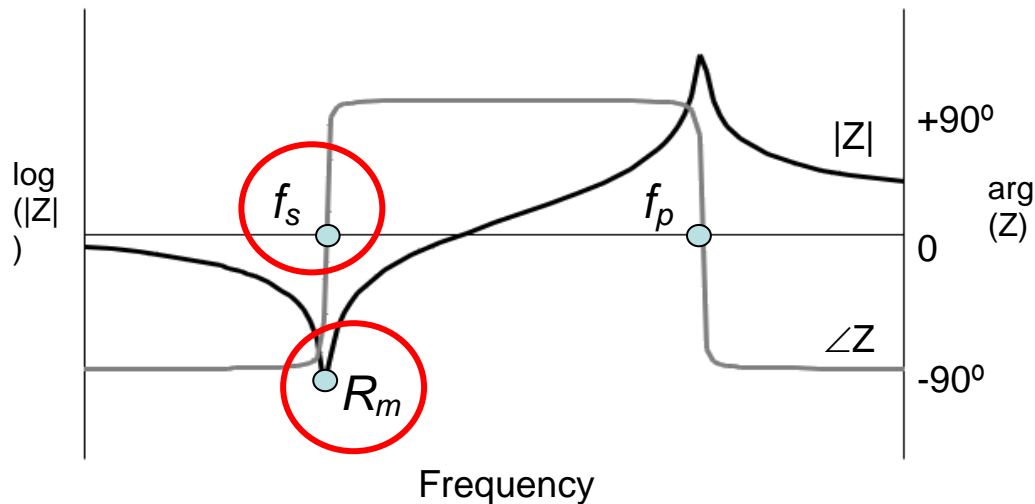

Figure 5. The impedance spectrum from which the two main characteristics are extracted (motional resistance R_m and resonant frequency f_s)

The Biosensor laboratory at the University of Toronto is the only one in the world studying conformational changes in biomolecules and cellular behaviour using high-resolution sensor platforms over the last three decades.

Discussion

We do not have a clear definition for life yet. What makes the difference between a living cell and an identical cell, without life? All the physical properties are identical, the chemical components are the same, what is missing is the ineffable force that moves everything in the most surprisingly coherent fashion. What orchestrates 100,000 chemical reactions, every second, in every cell of the 100 trillion that form a human body? How can the constant homeostatic feedback response be achieved in milliseconds? What coordinates the self-organization of this complex system? Is it driven by the 25,000 genes turning each other on and off and producing proteins? Decoding the human genome did not reveal a Holy Grail after all: the contribution of the gene variants to disease is rather weak. There are other unknown factors at work and the challenge ahead is to identify these, their controls, their potential impact and interactions.

Science is unable to explain how mental processes such as creativity, intuition, insight, thinking, emotions and the feeling of being alive arise from electrochemical impulses firing along neural axons. Great scientific minds of the modern era – Niels Bohr, Erwin Schrödinger, Wolfgang Pauli, Paul Dirac, Werner Heisenberg, Max Plank, David Bohm and others – realized long ago that quantum physics could not be understood unless consciousness was included as a primary component of fundamental reality. If both mind and physical body have a common quantum nature, their interaction could eventually be explained and the way in which a non-material thought generates a cascade of material chemicals - neuropeptides, immune and endocrine reactions - is easier to grasp. Nonlocal instant coordination can also be seen as taking place through quantum entanglement mechanisms. However, quantum physics cannot accommodate feelings in the symbols of its differential equations. Neuroscientists can see the activity in distinct areas of the brain, but how this is constructed and bound together in unitary experiences and feelings still remains elusive. How can the nonmaterial mind influence the material body? Is consciousness the substrate of both, conceiving, forming and becoming biology, so interaction happens naturally? It was said that the non-physical cannot be measured by employing physical instruments. However, experiments using high-frequency vibrational fields, such the one briefly explained above, can detect the strong effects of human intention on populations of neuron cells grown to form a living neural network on the surface of a high resolution sensing device. It seems to be a perfectly measurable, quantifiable interaction.

Proposed measurements

One focus of our research is to use vibrational fields to study biological samples, from DNA and protein to living cells and tissues. Decades of expertise in using fields of variable frequencies allow us to open a new window on biological mechanisms. The methods are non-invasive and label-free, the monitoring of properties, structure and function takes place in real time, it is integrative and sophisticated, and uses modern techniques which transfer the limited spatial and temporal resolution into frequency and amplitude signals at extremely high resolution. The goal of this particular proposal is to further refine the understanding of how human consciousness interacts with living matter and, if possible, to quantify this interaction.

The healer's report of color and intensity changes around the neurons during the experiment presented here might be checked with cameras that detect the biophotons emitted by the DNA. This is a tremendous opportunity, since the emission of biophotons from a healthy tissue compared to the nearby diseased tissue (cancer) seems to have a higher degree of coherence.⁷ Is coherence a degree of health? The simple fact that our DNA can emit coherent biophotons is remarkable. Light is coherent only in lasers: all the photons travel in phase through space. How, then, we may ask, does a DNA molecule generate laser-like energy, even if it is at extremely low intensities? Is there a solitonic excitation mechanism involved? A non-local holographic transfer of morphogenetic information? Can it be used for regenerative purposes to reverse diseased organism structures by imposing the correct, super-coherent information matrix? We know that the periodic structure of the DNA can theoretically generate frequencies in the high domain

of the spectrum, 54 to 78 GHz (animal DNA at 47 and plant DNA at 42 GHz). Between the 2 limits for humans, 27 billion characteristic frequencies can be accommodated due to differences in the DNA of each person. Is this the way we are identified by the field of consciousness?

THE FOLLOW-UP EXPERIMENT

PRIMARY VARIABLES IN THE EXPERIMENT:

1. Intention of the subject
2. Personal ability for volition and concentration

OBJECTIVES TO EXPLORE:

1. Investigation of the consistency of results with the same subject (repeatability)
2. Comparative assessment of the results achieved with different subjects
3. Extent to which the results depend on the subject's belief in the possibility of influencing living matter with the power of the mind (two groups of subjects, SHEEP/believers and GOATS/nonbelievers, will be assessed)
4. Does combining the influence of more than one subject reinforce the overall effect?
5. Does physical separation, i.e. the distance from the neurons make any difference? Study of focused intentionality at distance: the experimenter will be blind to the exact time when the remote subject will actually start to focus
6. Do the results depend on psychological characteristics of the subjects? On age or physiological characteristics?
7. Does the coherence of the biophotons emitted by the neurons change during the experiment? A biophotonic camera will be needed to perform such measurements.
8. Does earthing change the vitality and strengths of the neurons? Will they respond differently to neurotoxins, vasopressin, cortisol, environmental changes or the influence of human mind? Comparative measurement will be performed on neurons or other cells grown in earthed and unearthed Petri dishes.

10. Do patients who suffered frontal lobe damage lack the filters that impede “normal” people to mentally influence physical instruments? A patient with missing front lobe tissue who collaborates already with the Baycrest Hospital team of neuroscientists led by Dr. Morris Freedman, will be invited to the lab in order to study the influence of altered mind filters on the capability to influence the neurons. We can later repeat the measurement at a distance.

EXPERIMENTAL MODEL ADVANTAGES:

1. The sensor device provides a real-time quantitative recording which constitutes an attractive feedback for the researchers
2. The output is simple, direct and calculable
3. The signal-to-noise ratio discrimination is very high and extreme protection against technical malfunctions, environmental artifacts and other spurious influences is provided
4. The system is capable of rapid acquisition and storage of very large bases of data.
5. Extensive calibration is performed before each measurement

PARTICIPANTS:

All subjects will benefit from a friendly experimental atmosphere and uninhibited participation in the performance, discussion and interpretation of the experiment. Any technical information will be provided at their request. We will maintain their anonymity. No compensation will be provided beyond their own satisfaction in participating in the work and a comfortable and relaxed environment. They will be regarded as full collaborators in the research.

REFERENCES

1. L.E. Cheran, S. Cheung, A. Al Chawaf, J. S. Ellis, Denise D. Belsham, W. A. MacKay, D. Lovejoy, M. Thompson, “Label-free detection of neuron–drug interactions using acoustic and Kelvin vibrational fields”, *Analyst*, 2007, 132, 242 – 255.
2. Cheran, LE, Thompson, M. Neural Regenerative Medicine and Detection Strategies for Neurochemistry, *J. Nanoneurosci.* 1, 1–16, 2009
3. Cheran LE, et al., (2004) Protein microarray scanning in label-free format by Kelvin nanoprobe. *Analyst* 129:161–168.

4. Cheran LE, et al., (2008) Probing the bioelectrochemistry of living cells. *Electrochimica Acta* 53:6690–6697.
5. Cheran LE, Benvenuto P, Thompson M (2008) Coupling of neurons with biosensor devices for detection of the properties of neuronal populations. *Chem Soc Rev* 37:1229–1242.
6. M. Yang and M. Thompson, "Acoustic network analysis and equivalent circuit simulation of the thickness-shear mode acoustic wave sensor in the liquid phase", *Analytica Chimica Acta*, 282, 505 (1993).
7. F. A. Popp and J. J. Chang, Biological Organization: a Possible Mechanism Based on the Coherence of Biophotons, in *Biophotons*, edited by JJ Chang, J Fisch and F-A Popp, Kluwer Academic Publishers, Dordrecht, the Netherlands, 1998

Larissa-Emilia Cheran is a Senior Research Scientist involved in the interdisciplinary and integrative study of biology using acoustic and electromagnetic vibrational field. Her main focus is brain regeneration at molecular and cellular level. Her next book, "Sensor Technology in Neuroscience" presents system technology and detection methods for brain research.